

PL 240 PL 240LM

BOX WAY TYPE TURNING CENTER

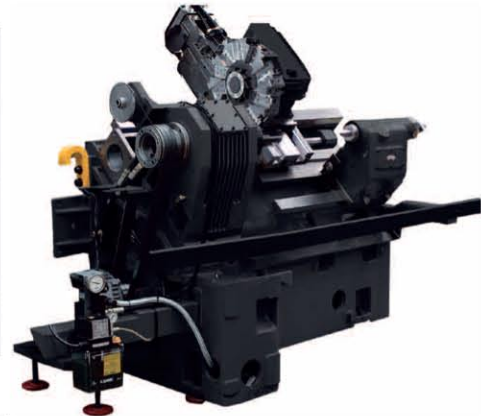
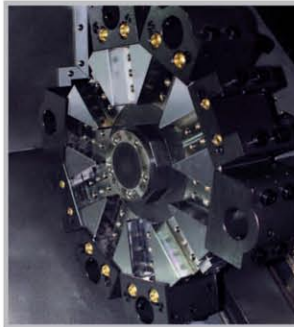
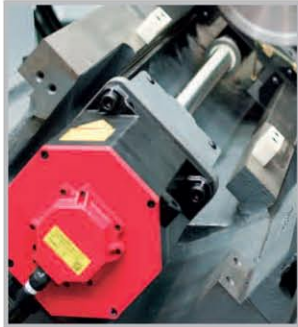

PL 240

Focused on stabilized management and sustainability



The strongest spindle power in similar spec. machine
 adaptation broad and stabilized motor
 compact size
 The smallest floor space in similar spec. machine

Major Specifications

[] : Option

DESCRIPTION		PL 240	PL 240LM
Swing over the bed	mm	∅ 510	∅ 510
Max. machining diameter × length	mm	∅ 350 × 540	∅ 350 × 540
Max. machining bar size	mm	∅ 66	∅ 52 [∅ 66]
Chuck size	inch	8	8
Spindle speed	rpm	4,000	4,000
Spindle nose	ASA	A2-6"	A2-6"
Spindle motor(cont./30min)	kW	15/18.5	11/15
Rapid traverse (X/Z)	m/min	24/24	24/24
Axis travel (X/Z)	mm	200/560	200/560
Number of tool positions	ea	10	12/BMT55
Shank size for square tool	mm	25 × 25	25 × 25
Shank size for boring bar	mm	∅ 40	∅ 40
Tailstock travel	mm	80	80
Machine weight	kgf	4,000	4,000
Required floor space (L × W)	mm	2,805 × 1,444	2,753 × 1,560
Controller		Fanuc Oi-TD [Fanuc Oi-Mate TD]	